

# gregory Model RR-EX

## Rider Reach Explosion Proof Truck Specifications for 5,000 lb. and 6,000 lb. Capacities

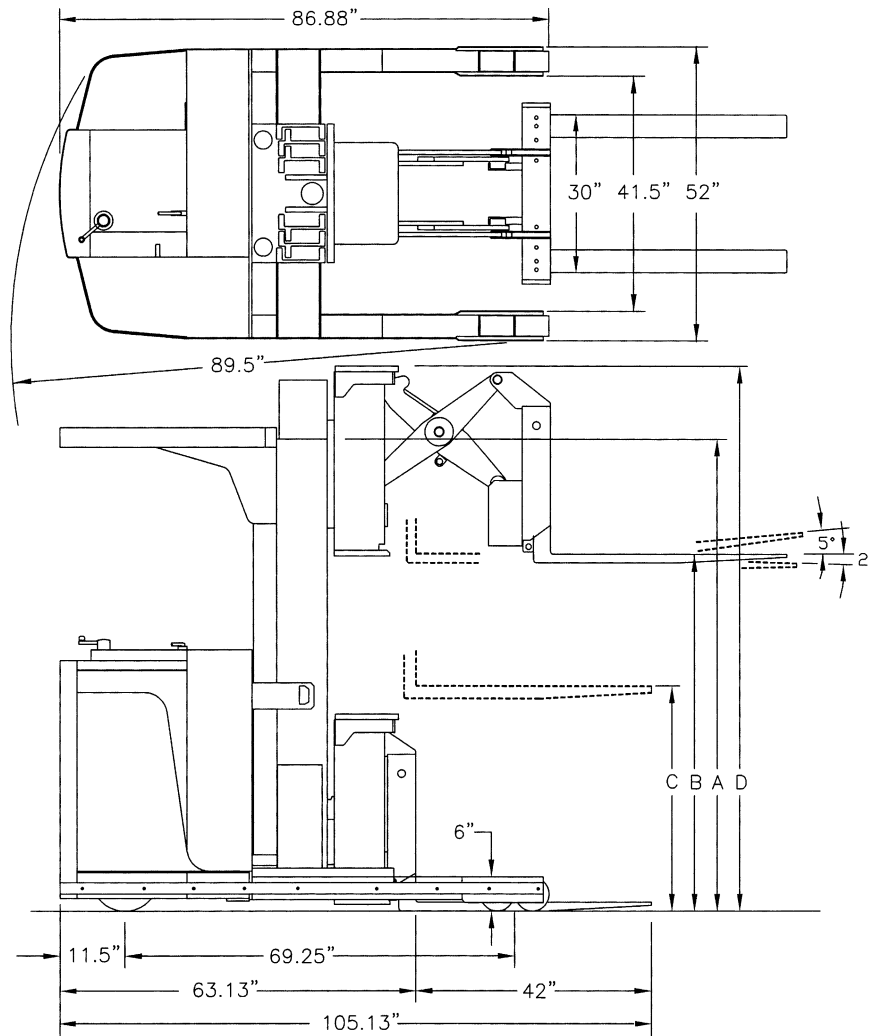

Standard Mast Specifications (inches)

Mast Type	(A) Collapsed Height	(B) Maximum Fork Height	(C) Free Lift	(D) Overall Extended Height
Standard	71	103.5	5.5	136.5
	83	127.5	5.5	160.5
Duplex	77	115.5	43	148.5
	83	127.5	49	160.5
Triplex	77	170	43	203
	83	183	49	221
	87	193	53	231
	89	197	55	235

★ All Gregory Explosion Proof (EX) rated forklifts can be custom designed in accordance with the individual specifications of each customer.

★ Specifications on this sheet provide standard dimensions for the 5,000 lb. and 6,000 lb. capacity RR models. Other capacities are available.

★ Contact the Excalibur Equipment Sales Department for custom requirements or special mast specifications.

Classified to U.S. and Canadian Safety Standards by Underwriters Laboratories Inc. for Use in Class I, Divisions 1 & 2, Groups C & D; Class II, Divisions 1 & 2, Group G; and Class III, Divisions 1 & 2 Hazardous Environments.



Rider Reach Explosion Proof Truck		
<b>General Information</b>	<b>Manufacturer</b>	Excalibur Equipment, LLC
	<b>Model</b>	Gregory RR5EX and RR6EX
	<b>Capacity</b>	RR5EX - 5,000 lb. at 24" Load Center RR6EX - 6,000 lb. at 24" Load Center
	<b>Rating</b>	UL Classified Explosion Proof
	<b>Power</b>	24 Volt Electric
	<b>Electric Controls</b>	Transistorized, Solid State Infinitely Variable Programmable Speed, Acceleration and Plugging Capabilities
	<b>Hydraulic Controls</b>	Point of Action Electric / Hydraulic Infinitely Variable
	<b>Motors (Drive, Lift, Power Steering)</b>	Heavy Duty Explosion Proof with Class "H" Insulation, UL Classified
	<b>Power Steering</b>	Hydrostatic
	<b>Forks (Bronze Covered)</b>	RR5EX - Shaft Mount 1.75 x 4.25 x 42 RR6EX - Shaft Mount 2.25 x 5.25 x 42 Other Sizes Available
	<b>Truck Weight (Less Battery)</b>	5,450 lb.
<b>Paint</b>	Safety Yellow	
<b>Dimensions</b>	<b>Specifications and Mast Options Shown on Front</b>	
<b>Performance</b>	<b>Maximum Travel Speeds</b>	4.8 mph Empty, 4.0 mph Loaded Programmable
	<b>Lift / Lower Speeds</b>	<b>Standard:</b> 50 / 75 fpm Empty 40 / 75 fpm Loaded <b>Duplex Hi-Free Lift:</b> 50 / 75 fpm Empty 35 / 75 fpm Loaded <b>Triplex:</b> 50 / 75 fpm Empty 35 / 75 fpm Loaded
	<b>Equal Intersecting Aisle</b>	79"
	<b>Right Angle Stacking</b>	113"
	<b>Gradeability</b>	10%
	<b>Chassis</b>	<b>Wheels, Drive</b>
	<b>Wheels, Load</b>	(4) 6" x 3.63" Polyurethane
	<b>Brake</b>	Deadman Foot Pedal
	<b>Underclearance</b>	2" Standard Higher Ramp Underclearances Available
<b>Battery and Charger Requirements</b>	<b>Battery Type</b>	UL Classified Explosion Proof
	<b>Battery Capacity</b>	500 Amp Standard - 620 Amp Available
	<b>Battery Compartment</b>	11.25" x 25.6" x 34.5" Side Removal
	<b>Battery Weight</b>	985 lbs.
	<b>Charger Connector</b>	N2106 Explosion Proof

Excalibur Equipment produces a complete line of specialized Material Handling Equipment. Continuous improvements in safety, performance and durability assure customers of a quality forklift designed to meet their specifications.

All vehicles are furnished with UL mandated safety devices and under no circumstances should these devices be removed. Gregory products and specifications are subject to improvements and changes without notice and obligation on prior purchases.

**Standard Features**  
 24 Volt System  
 Battery Discharge Indicator w/ Lift Interrupt  
 Sight Glass  
 Battery Roller Tray  
 Bronze Anti-Spark Package  
 Electric Horn and Back-Up Alarm Package  
 Emergency Power Disconnect  
 Hourmeter  
 Hydrostatic Power Steering  
 Internal Mast Reeving  
 Overhead Guard  
 Static Conductive Drive Tires  
 Transistorized Controls

**Optional Features**  
 Epoxy Paint  
 Hand Held Analyzer  
 Hydraulic Attachments  
 On/Off Key Switch  
 Remote In-Environment Charging Station  
 Stainless Steel Construction  
 Strobe Light

**Gregory EX Trucks** are Classified to U.S. and Canadian safety standards by Underwriters Laboratories Inc. for use in **Class I, Divisions 1 & 2, Groups C & D; Class II, Divisions 1 & 2, Group G; and Class III, Divisions 1 & 2** Environments.

All Gregory EX trucks are classified by UL to the following Standards for Safety:

**UL 583**  
 Electric-Battery-Powered Industrial Trucks

**UL 1203**  
 Explosion Proof and Dust-Ignition-Proof Electrical Equipment for Use in Hazardous (Classified) Locations

**UL 1604**  
 Electrical Equipment for Use in Class I and Class II, Division 2, and Class III Hazardous (Classified) Locations

## EXCALIBUR EQUIPMENT, LLC

285 Eldridge Road Fairfield, NJ 07004-2508  
 phone: (973) 808-8399 fax: (973) 808-8398  
[www.exequipment.com](http://www.exequipment.com)  
[sales@exequipment.com](mailto:sales@exequipment.com)