

gregory Model WT-EX

Rider Tugger Explosion Proof Truck Specifications for 800 lb. Towbar Pull

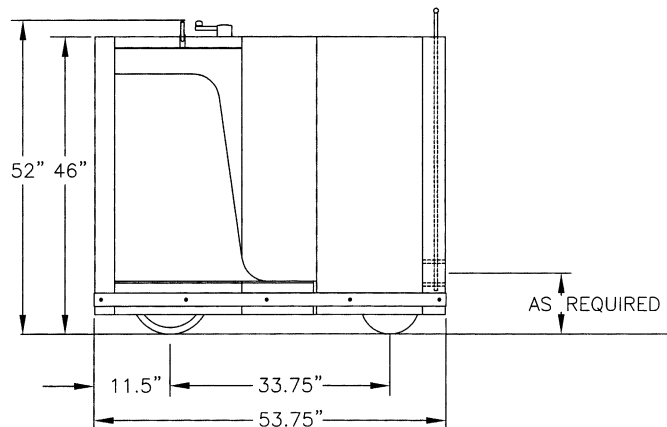
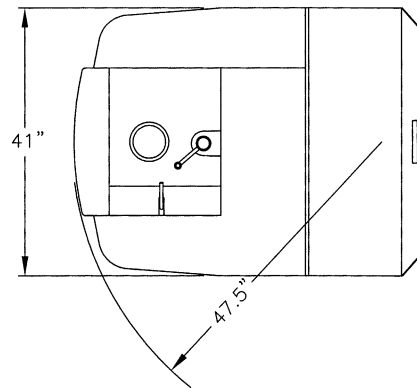

★ All Gregory Explosion Proof (EX) rated forklifts can be custom designed in accordance with the individual specifications of each customer.

★ Specifications on this sheet provide standard dimensions for 800 lb. towbar pull RT model.

★ Contact the Excalibur Equipment Sales Department for custom requirements or special platform sizes.

Classified to U.S. and Canadian Safety Standards by Underwriters Laboratories Inc. for Use in Class I, Divisions 1 & 2, Groups C & D; Class II, Divisions 1 & 2, Group G; and Class III, Divisions 1 & 2 Hazardous Environments.



Rider Tugger Explosion Proof Truck

General Information	Manufacturer	Excalibur Equipment, LLC
	Model	Gregory RTEX
	Capacity	800 lb. Towbar Pull, Up to 40,000 lb. Rolling Weight
	Rating	UL Classified Explosion Proof
	Power	24 Volt Electric
	Electric Controls	Transistorized, Solid State Infinitely Variable Programmable Speed, Acceleration and Plugging Capabilities
	Motors (Drive, Power Steering)	Heavy Duty Explosion Proof with Class "H" Insulation, UL Classified
	Hitch	Pin
	Truck Weight (Less Battery)	1,525 lbs.
	Paint	Safety Yellow
Dimensions	Shown on Front	
Performance	Maximum Travel Speeds	4.8 mph Empty, 3.2 mph Loaded Programmable
	Equal Intersecting Aisle	47.5" Chassis Only
	Right Angle Stacking	60" Chassis Only
	Gradeability	10%
Chassis	Wheels, Drive	(2) 12" x 3.5" Static Conductive Rubber
	Wheels, Load	(2) 6" x 3" High Durometer Polyurethane
	Brake	Deadman Foot Pedal
	Underclearance	2.5" Standard Higher Ramp Underclearances Available
Battery and Charger Requirements	Battery Type	UL Classified Explosion Proof
	Battery Capacity	500 Amp Standard - 620 Amp Available
	Battery Compartment	11.25" x 34.75" x 34.25" Side Removal
	Battery Weight	985 lbs.
	Charger Connector	N2106 Explosion Proof

Excalibur Equipment produces a complete line of specialized Material Handling Equipment. Continuous improvements in safety, performance and durability assure customers of a quality forklift designed to meet their specifications.

All vehicles are furnished with UL mandated safety devices and under no circumstances should these devices be removed. Gregory products and specifications are subject to improvements and changes without notice and obligation on prior purchases.

Standard Features
 24 Volt System
 Battery Discharge Indicator
 Sight Glass
 Battery Roller Tray
 Pin Type Hitch
 Bronze Anti-Spark Package
 Electric Horn and Back-Up Alarm Package
 Emergency Power Disconnect
 Hourmeter
 Hydrostatic Power Steering
 Polyurethane Load Wheels
 Static Conductive Drive Tires
 Transistorized Controls

Optional Features
 12 Volt System (shortens wheelbase)
 Custom Designed Hitch
 Epoxy Paint
 Hand Held Analyzer
 On/Off Key Switch
 Remote In-Environment Charging Station
 Stainless Steel Construction
 Strobe Light (pedestal mounted)

Gregory EX Trucks are Classified to U.S. and Canadian safety standards by Underwriters Laboratories Inc. for use in **Class I, Divisions 1 & 2, Groups C & D; Class II, Divisions 1 & 2, Group G; and Class III, Divisions 1 & 2** Environments.

All Gregory EX trucks are classified by UL to the following Standards for Safety:

UL 583

Electric-Battery-Powered Industrial Trucks

UL 1203

Explosion Proof and Dust-Ignition-Proof Electrical Equipment for Use in Hazardous (Classified) Locations

UL 1604

Electrical Equipment for Use in Class I and Class II, Division 2, and Class III Hazardous (Classified) Locations

EXCALIBUR EQUIPMENT, LLC

285 Eldridge Road Fairfield, NJ 07004-2508
 phone: (973) 808-8399 fax: (973) 808-8398
www.exequipment.com
sales@exequipment.com