

# gregory Model WR-EX

## Walkie Reach Explosion Proof Truck Specifications for 3,000 lb. Capacity

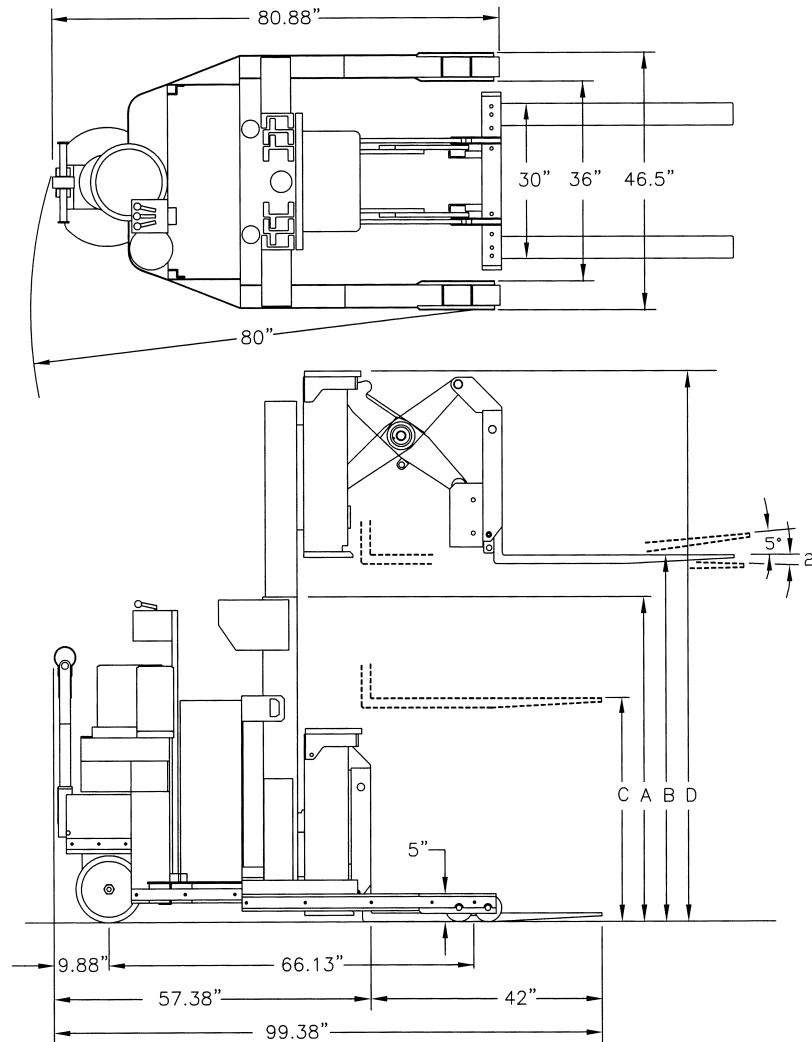

Standard Mast Specifications (inches)

Mast Type	(A) Collapsed Height	(B) Maximum Fork Height	(C) Free Lift	(D) Overall Extended Height
Standard	71	103.5	5.5	136.5
	83	127.5	5.5	160.5
Duplex	77	115.5	43	148.5
	83	127.5	49	160.5
Triplex	77	170	43	203
	83	188	49	221
	87	198	53	231
	89	202	55	235

★ All Gregory Explosion Proof (EX) rated forklifts can be custom designed in accordance with the individual specifications of each customer.

★ Specifications on this sheet provide standard dimensions for 3,000 lb. capacity WR models. Capacities to 6,000 lb. are available.

★ Contact the Excalibur Equipment Sales Department for custom requirements or special mast specifications.

Classified to U.S. and Canadian Safety Standards by Underwriters Laboratories Inc. for Use in Class I, Divisions 1 & 2, Groups C & D; Class II, Divisions 1 & 2, Group G; and Class III, Divisions 1 & 2 Hazardous Environments.



Walkie Reach Explosion Proof Truck		
<b>General Information</b>	<b>Manufacturer</b>	Excalibur Equipment, LLC
	<b>Model</b>	Gregory WR3EX
	<b>Capacity</b>	WR3EX - 3,000 lb. at 24" Load Center
	<b>Rating</b>	UL Classified Explosion Proof
	<b>Power</b>	24 Volt Electric
	<b>Electric Controls</b>	Transistorized, Solid State Infinitely Variable Programmable Speed, Acceleration and Plugging Capabilities
	<b>Hydraulic Controls</b>	Point of Action Electric / Hydraulic Infinitely Variable
	<b>Motors (Drive, Lift)</b>	Heavy Duty Explosion Proof with Class "H" Insulation, UL Classified
	<b>Forks (Bronze Covered)</b>	Shaft Mount 1.75 x 4.25 x 42 Other Sizes Available
	<b>Truck Weight (Less Battery)</b>	3,725 lb.
<b>Paint</b>	Safety Yellow	
<b>Dimensions</b>	<b>Specifications and Mast Options Shown on Front</b>	
<b>Performance</b>	<b>Maximum Travel Speeds</b>	4.8 mph Empty, 4 mph Loaded Programmable
	<b>Lift / Lower Speeds</b>	<b>Standard:</b> 55 / 35 fpm Empty 45 / 50 fpm Loaded <b>Duplex Hi-Free Lift:</b> 55 / 40 fpm Empty 40 / 50 fpm Loaded <b>Triplex:</b> 55 / 60 fpm Empty 40 / 55 fpm Loaded
	<b>Equal Intersecting Aisle</b>	79"
	<b>Right Angle Stacking</b>	103"
	<b>Gradeability</b>	10%
	<b>Chassis</b>	<b>Wheels, Drive</b>
	<b>Wheels, Load</b>	(4) 5" x 3.63" Polyurethane
	<b>Brake</b>	Spring Loaded Handle Return Heavy Duty Disc Brake
	<b>Underclearance</b>	2" Standard Higher Ramp Underclearances Available
<b>Battery and Charger Requirements</b>	<b>Battery Type</b>	UL Classified Explosion Proof
	<b>Battery Capacity</b>	500 Amp Standard - 620 Amp Available
	<b>Battery Compartment</b>	11.25" x 34.75" x 34.25" Overhead Removal
	<b>Battery Weight</b>	985 lbs.
	<b>Charger Connector</b>	N2106 Explosion Proof

Excalibur Equipment produces a complete line of specialized Material Handling Equipment. Continuous improvements in safety, performance and durability assure customers of a quality forklift designed to meet their specifications.

All vehicles are furnished with UL mandated safety devices and under no circumstances should these devices be removed. Gregory products and specifications are subject to improvements and changes without notice and obligation on prior purchases.

**Standard Features**  
 24 Volt System  
 Battery Discharge Indicator w/ Lift Interrupt  
 Sight Glass  
 Bronze Anti-Spark Package  
 Emergency Power Disconnect  
 Hourmeter  
 Internal Mast Reeving  
 Static Conductive Drive Tires  
 Transistorized Controls

**Optional Features**  
 Battery Roller Tray  
 Electric Horn and Back-Up Alarm Package  
 Epoxy Paint  
 Hand Held Analyzer  
 Hydraulic Attachments  
 On/Off Key Switch  
 Operator Toe Guard  
 Remote In-Environment Charging Station  
 Stainless Steel Construction  
 Strobe Light

**Gregory EX Trucks** are Classified to U.S. and Canadian safety standards by Underwriters Laboratories Inc. for use in **Class I, Divisions 1 & 2, Groups C & D; Class II, Divisions 1 & 2, Group G; and Class III, Divisions 1 & 2** Environments.

All Gregory EX trucks are classified by UL to the following Standards for Safety:

**UL 583**  
 Electric-Battery-Powered Industrial Trucks

**UL 1203**  
 Explosion Proof and Dust-Ignition-Proof Electrical Equipment for Use in Hazardous (Classified) Locations

**UL 1604**  
 Electrical Equipment for Use in Class I and Class II, Division 2, and Class III Hazardous (Classified) Locations

## EXCALIBUR EQUIPMENT, LLC

285 Eldridge Road Fairfield, NJ 07004-2508  
 phone: (973) 808-8399 fax: (973) 808-8398  
[www.exequipment.com](http://www.exequipment.com)  
[sales@exequipment.com](mailto:sales@exequipment.com)