

gregory Model WR-EX

Walkie Reach Explosion Proof Truck Specifications for 5,000 lb. and 6,000 lb. Capacities

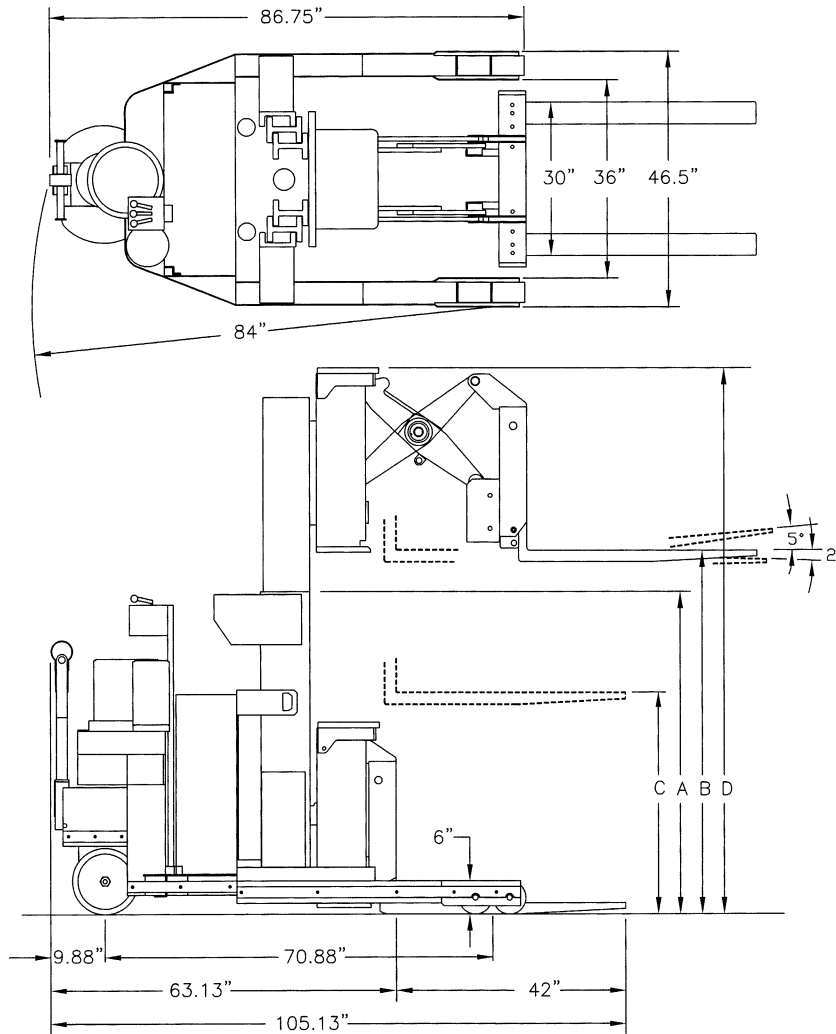

Standard Mast Specifications (inches)

Mast Type	(A) Collapsed Height	(B) Maximum Fork Height	(C) Free Lift	(D) Overall Extended Height
Duplex	71.5	93	37.5	126
	83.5	120	49.5	153
Triplex	77.5	158	43.5	191
	83.5	176	49.5	209
	87.5	186	53.5	219
	91.5	195	57.5	228

★ All Gregory Explosion Proof (EX) rated forklifts can be custom designed in accordance with the individual specifications of each customer.

★ Specifications on this sheet provide standard dimensions for 5,000 lb. and 6,000 lb. capacity WR models. Other capacities are available.

★ Contact the Excalibur Equipment Sales Department for custom requirements or special mast specifications.

Classified to U.S. and Canadian Safety Standards by Underwriters Laboratories Inc. for Use in Class I, Divisions 1 & 2, Groups C & D; Class II, Divisions 1 & 2, Group G; and Class III, Divisions 1 & 2 Hazardous Environments.



Walkie Reach Explosion Proof Truck		
General Information	Manufacturer	Excalibur Equipment, LLC
	Model	Gregory WR5EX and WR6EX
	Capacity	WR5EX - 5,000 lb. at 24" Load Center WR6EX - 6,000 lb. at 24" Load Center
	Rating	UL Classified Explosion Proof
	Power	24 Volt Electric
	Electric Controls	Transistorized, Solid State Infinitely Variable Programmable Speed, Acceleration and Plugging Capabilities
	Hydraulic Controls	Point of Action Electric / Hydraulic Infinitely Variable
	Motors (Drive, Lift)	Heavy Duty Explosion Proof with Class "H" Insulation, UL Classified
	Forks (Bronze Covered)	WR5EX - Shaft Mount 1.75 x 4.25 x 42 WR6EX - Shaft Mount 2.25 x 5.25 x 42 Other Sizes Available
	Truck Weight (Less Battery)	3,950 lb.
	Paint	Safety Yellow
Dimensions	Specifications and Mast Options Shown on Front	
Performance	Maximum Travel Speeds	4.8 mph Empty, 4 mph Loaded Programmable
	Lift / Lower Speeds	Standard: 40 / 35 fpm Empty 30 / 50 fpm Loaded Duplex Hi-Free Lift: 35 / 25 fpm Empty 25 / 50 fpm Loaded Triplex: 45 / 35 fpm Empty 30 / 50 fpm Loaded
	Equal Intersecting Aisle	81"
	Right Angle Stacking	106"
	Gradeability	10%
Chassis	Wheels, Drive	(2) 12" x 3.5" Static Conductive Rubber
	Wheels, Load	(4) 6" x 3.63" Polyurethane
	Brake	Spring Loaded Handle Return Heavy Duty Disc Brake
	Underclearance	2" Standard Higher Ramp Underclearances Available
Battery and Charger Requirements	Battery Type	UL Classified Explosion Proof
	Battery Capacity	500 Amp Standard - 620 Amp Available
	Battery Compartment	11.25" x 34.75" x 34.25" Overhead Removal
	Battery Weight	985 lbs.
	Charger Connector	N2106 Explosion Proof

Excalibur Equipment produces a complete line of specialized Material Handling Equipment. Continuous improvements in safety, performance and durability assure customers of a quality forklift designed to meet their specifications.

All vehicles are furnished with UL mandated safety devices and under no circumstances should these devices be removed. Gregory products and specifications are subject to improvements and changes without notice and obligation on prior purchases.

Standard Features
 24 Volt System
 Battery Discharge Indicator w/ Lift Interrupt
 Sight Glass
 Bronze Anti-Spark Package
 Emergency Power Disconnect
 Hourmeter
 Internal Mast Reeving
 Static Conductive Drive Tires
 Transistorized Controls

Optional Features
 Battery Roller Tray
 Electric Horn and Back-Up Alarm Package
 Epoxy Paint
 Hand Held Analyzer
 Hydraulic Attachments
 On/Off Key Switch
 Operator Toe Guard
 Remote In-Environment Charging Station
 Stainless Steel Construction
 Strobe Light

Gregory EX Trucks are Classified to U.S. and Canadian safety standards by Underwriters Laboratories Inc. for use in **Class I, Divisions 1 & 2, Groups C & D; Class II, Divisions 1 & 2, Group G; and Class III, Divisions 1 & 2** Environments.

All Gregory EX trucks are classified by UL to the following Standards for Safety:

UL 583
 Electric-Battery-Powered Industrial Trucks

UL 1203
 Explosion Proof and Dust-Ignition-Proof Electrical Equipment for Use in Hazardous (Classified) Locations

UL 1604
 Electrical Equipment for Use in Class I and Class II, Division 2, and Class III Hazardous (Classified) Locations

EXCALIBUR EQUIPMENT, LLC

285 Eldridge Road Fairfield, NJ 07004-2508
 phone: (973) 808-8399 fax: (973) 808-8398
www.exequipment.com
sales@exequipment.com