

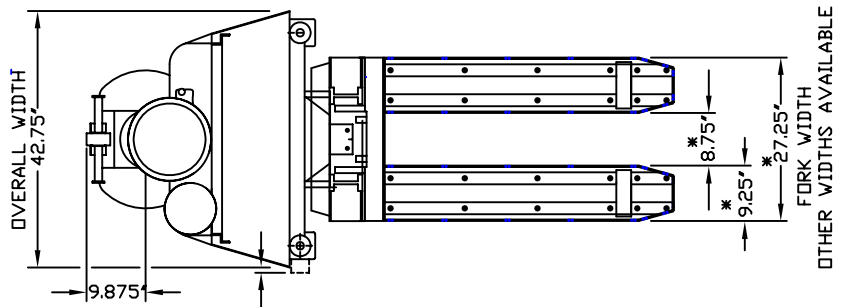

**MODEL # WSFEX  
WALKIE STACKER FORKOVER**

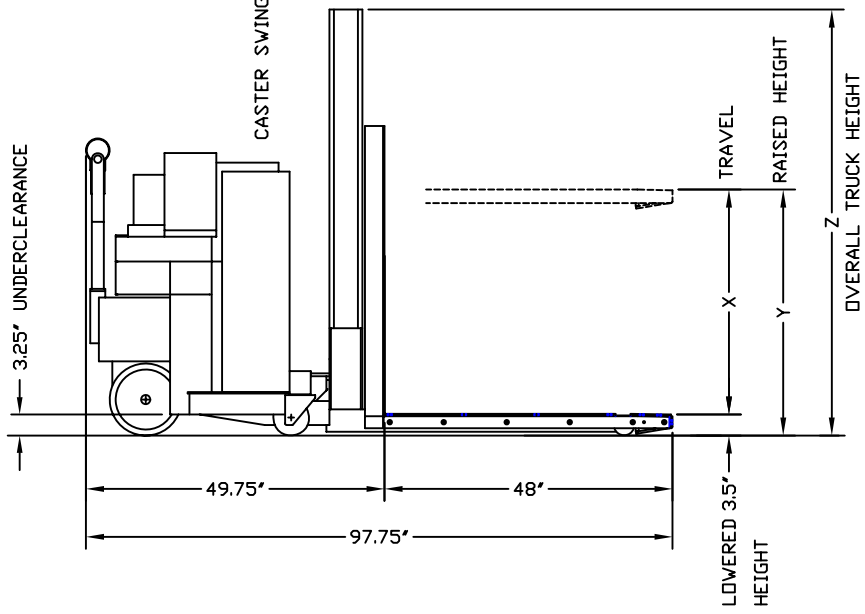

\* DESIGNATES FINISHED DIMENSIONS INCLUDING BRONZE STRIPS



X-Z ARE VARIABLES TO MEET CUSTOMER REQUIREMENTS.

CAPACITIES TO 8,000 LB.

**UL OF USA**

**POWER OPERATED INDUSTRIAL TRUCK**  
CLASSIFIED BY UNDERWRITERS LABORATORIES INC. AS TO FIRE,  
 ELECTRIC SHOCK AND EXPLOSION HAZARDS  
**CLASS I GROUP C & D, CLASS II GROUP G, & CLASS III, HAZARDOUS LOCATIONS**  
**TYPE EX INDUSTRIAL TRUCK**  
OPERATING TEMPERATURE CODE T3B NO. D-

---

**EXCALIBUR EQUIPMENT, LLC.**  
**GREGORY INDUSTRIAL TRUCKS.** FAIRFIELD, NJ 07004

**Class I Group C & D Locations-**

Locations in which flammable gases or vapors are, or may be, present in the air in quantities sufficient to produce explosive or ignitable mixtures, such as: Ethylene, Diethyl Ether, Methyl Ether, Gasoline, Naphtha, Alcohols, Acetone, Lacquer Solvent, Benzene, etc.

**UL OF CANADA**

**UNDERWRITERS' LABORATORIES OF CANADA**  
**LISTED POWER INDUSTRIAL TRUCK**  
**TYPE EX NO. C**  
INVESTIGATED WITH RESPECT TO FIRE, ELECTRICAL SHOCK  
 AND EXPLOSION HAZARDS.  
 (CLASS I GROUP C & D, CLASS II GROUP G, & CLASS III)

---

**EXCALIBUR EQUIPMENT, LLC.**  
**GREGORY INDUSTRIAL TRUCKS.** FAIRFIELD, NJ 07004

**Class II Group G Locations-**

Locations which are hazardous because of the presence of combustible dust, such as: Grain Dust, Flour Dust, Starch Dust, Organic Dust, etc.